

*...Only from Eriez*



### Features & Benefits:

- Electro-permanent magnet drive
- AC operation of most models
- Standard and custom trays
- Enclosed drive element
- Low power consumption
- Class II hazardous location drives available
- Available for washdown application
- High amplitude/low frequency available
- Available to USDA requirements
- CE and CSA approved models
- Solid-state controls

**ERIEZ®**

# Hi-Vi Compact Electromagnetic Feeders

## Full Line

A wide range of drive units for precision feeding of bulk materials.





# Hi-Vi Electromagnetic

Eriez' unique Hi-Vi magnetic drive circuit provides a simple yet powerful solution to difficult material feeding applications.

These feeders, with their totally enclosed patented magnetic drive, can feed practically any bulk material from micron size to bulky chunks. Solid-state controls operate the feeders with "watch-like" precision. In addition, you get all the features that for years have made Eriez Feeders the leaders in quality and dependability.

Eriez has standard models for the majority of feeding applications. Special units such as multiple drives, enclosed trays or screens can be designed for the best solution to your application. In addition, a wide variety of standard and special trays are available.

## Electro-Permanent Magnetic Drive

The basic simplicity of a drive powered by alternately opposing and attracting magnetic forces assures low maintenance. There are no sliding or rotating parts. Power consumption is low, installation easy. The positive driving force of Eriez units provides stability, control, and unexcelled accuracy.

## AC Operation For Most Models

No rectifiers are required; feeders are simply wired into AC lines.

## Simple Controls

Eriez electromagnetic feeder controls are reliable, state-of-the-art, solid-state units that deliver superior feed rate control. By varying the voltage to the feeder, coupled with Eriez AC circuit, excellent linearity is achieved. Standard controls come in NEMA 12 (IP54) enclosures. Special enclosures are also available. Controls can be provided with manual or automatic (analog signal) adjustment to address many applications. Special design controls are also available to address your unique requirements.

## Encapsulation

The coil and magnet in Eriez' drive unit are encapsulated in epoxy, eliminating coil movement and thus extending trouble – free coil life.

## Enclosed Drive Element

The completely enclosed drive element, dust and moisture resistant, extends coil life and makes external cleaning easier. Special enclosures are available for dusty locations where Class II, Group F and G equipment is normally used.

## High Temperature Units

Standard units operate at temperatures up to 130°F (54°C). High-temperature units are available for temperatures up to 300°F (150°C).

## The Patented Eriez Hi-Vi Magnetic Drive Circuit

Prior to Eriez revolutionary AC design, electromagnetic vibratory equipment operated with an inefficient attract release system: a spring – mounted moving mass is alternately attracted by a rectified pulsating DC electromagnet and returned to its original position solely by the springs. The Eriez HI-VI system, on the other hand, incorporates a lifetime permanent magnet (part of a spring-mounted moving mass) whose poles are intermeshed with those of an electromagnet powered directly by an AC line. This results in the spring-mounted moving mass being both attracted and repelled by the AC electromagnet equally on each half of the AC cycle.

In the diagram below, the poles of the permanent magnet are shown intermeshed in the air gaps of the AC electromagnet. The polarity of the permanent magnet is fixed, while the polarity of the electromagnet alternates at line frequency. The electromagnet polarity is shown as it exists on

one side of the AC sine wave; note that both poles of the permanent magnet are attracted toward the unlike electromagnet poles while being repelled in the same direction by the like poles. Thus there are four forces acting together to drive the armature and moving mass in the same direction.

The action described has the effect of progressively closing the magnetizing circuit through the electromagnet core, providing a progressively increasing magnetizing force upon the permanent magnet. The demagnetizing force is very minor, since the action described also has the effect of progressively opening the demagnetizing circuit.

On the opposite side of the sine wave the polarities of the electromagnet are reversed, the armature is driven in the opposite direction, and again there is a net magnetizing force on the permanent magnet. There is always a predominant magnetizing force impressed upon the permanent magnet that prevents it from ever losing its strength.

Since the amplitude of vibration depends directly upon the forces applied at the poles, and since these forces depend directly upon the applied AC voltage, simple variation of the AC voltage from zero to maximum results in similar amplitude variation from zero to maximum.

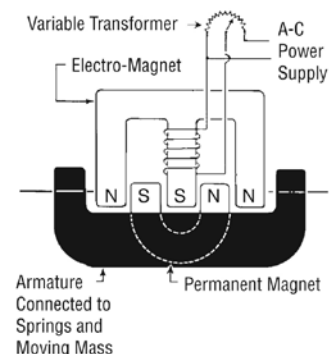

Figure 1. Eriez Magnetic Drive Circuit



## Model 6C

FOR FEEDING UP TO 1,600 POUNDS (727 KG) PER HOUR

Light capacity feeder ideal for applications demanding top performance at budget prices. Common applications include metering small quantities of dry materials or conveying small parts.



Power Supply	115V, 60 Cycle, Single Phase
Full Load Power Consumption	15 Watts
Full Load Power Input	.35 Amp at 115V
Control	Model VC-5
Net Feeder Weight	13.51 lb. (6.2 kg)

## Model 15A

FOR FEEDING UP TO 2 TONS (1.8 MT) PER HOUR

The smallest AC feeder in the line, this economical model will give precise feeding of the most minute amounts of materials. It is ideal for additive feeding, small packaging operations and laboratory use.



Power Supply	115V, 60 Cycle, Single Phase
Full Load Power Consumption	15 Watts
Full Load Power Input	0.5 Amp at 115V
Control	Model FT
Net Feeder Weight	25 lb. (11 kg)

## Specifications

### MODEL 6C

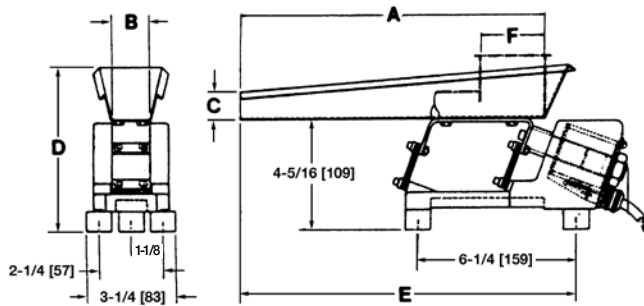

TRAY TYPE	A Tray Length		B Tray Width		C	
	in	mm	in	mm	in	mm
Narrow Flat	12	304	1-1/2	38	1-1/16	27
Wide Flat	8	203	2	51	1-1/16	27
90 Degree V	12	304	-	-	11/16	18
Small Tubular	12	304	1 (DIA.)	25	-	-

TRAY TYPE	D		E		F	
	in	mm	in	mm	in	mm
Narrow Flat	6-3/8	162	13-5/16	338	-	-
Wide Flat	6-3/8	162	9-13/16	249	-	-
90 Degree V	6-3/8	162	13-5/16	338	-	-
Small Tubular	5-13/16	148	13-5/16	338	1-3/4	44

### MODEL 15A

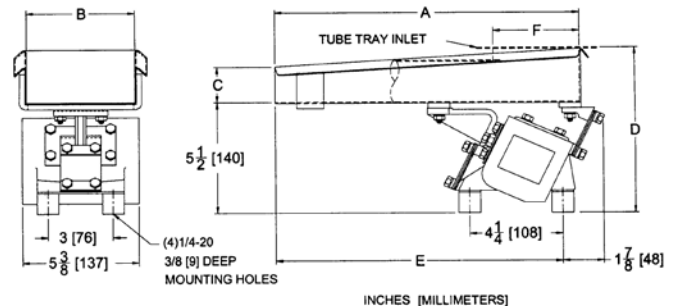

TRAY TYPE	A Tray Length		B Tray Width		C	
	in	mm	in	mm	in	mm
Narrow Flat	16	406	2	51	1	25
Medium Flat	20	508	4	102	1-3/4	44
Wide Flat	14	356	7	178	1-3/4	44
Small Tubular	19	483	2	51	2	50
90 Degree V	20	508	3	76	1-1/2	38
Half Round	20	508	3	76	1-1/2	38

TRAY TYPE	D		E		F	
	in	mm	in	mm	in	mm
Narrow Flat	7-1/2	191	15-1/4	387	-	-
Medium Flat	8-1/8	206	19-1/4	489	-	-
Wide Flat	8-1/8	206	13-1/4	337	-	-
Small Tubular	8	203	18-1/4	464	4	102
90 Degree V	8	203	19-1/4	489	-	-
Half Round	8	203	19-1/4	489	-	-



## Model 26C

FOR FEEDING UP TO 4 TONS (3.6 MT) PER HOUR

A rugged AC-operated unit for linear, accurate feeding of large quantities of bulk materials such as flakes, lumps and grains.



Power Supply	115V, 50-60 Cycle, Single Phase
Full Load Power Consumption	18 Watts
Full Load Power Input	1.1 Amp at 115V
Control	Model FT
Net feeder Weight	42 lb. (19 kg)

## Specifications

### MODEL 26C

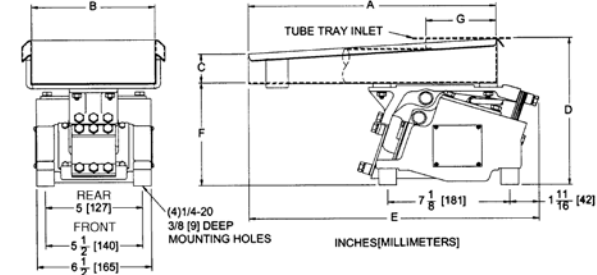

TRAY TYPE	A Tray Length		B Tray Width		C	
	in	mm	in	mm	in	mm
Narrow Flat	20	508	4	102	1-3/4	44
Medium Flat	22	559	5	127	1-3/4	44
Wide Flat	14	356	7	178	1-3/4	44
Wide Flat	20	508	7	178	1-3/4	44
90 Degree V	20	508	3	76	1-1/2	38
90 Degree V	20	508	4	102	2	51
Small Tubular	19	483	2	51	2	51
Large Tubular	19	483	3	76	3	76

TRAY TYPE	D		E		F		G	
	in	mm	in	mm	in	mm	in	mm
Narrow Flat	8-7/8	225	22-7/16	570	6-1/4	159	-	-
Medium Flat	9	229	22	559	6-1/4	159	-	-
Wide Flat	8-7/8	225	16-7/16	418	6-1/4	159	-	-
Wide Flat	9	229	20	509	6-1/4	159	-	-
90 Degree V	8-13/16	224	22-7/16	570	6-5/16	160	-	-
90 Degree V	9-3/8	237	20	509	6-3/8	161	-	-
Small Tubular	8-3/4	222	21-7/16	545	6-1/4	159	4	102
Large Tubular	10	254	19	484	6-1/4	159	6	152

Available for Class II, Division I, Group F, G Environments.

## Model 36C

FOR FEEDING UP TO 7 TONS (6.3 MT) PER HOUR

All of these models are completely enclosed so the drive element is protected against damage or decreased efficiency due to contamination by moisture and foreign materials. Special construction is also available for installation in those areas where Class II, Group F and G equipment would normally be used.

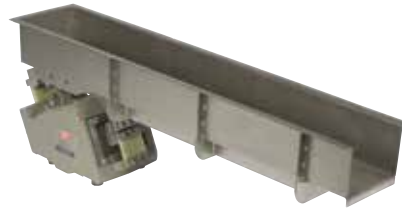

Power Supply	115V, 60 Cycle, Single Phase
Full Load Power Consumption	38 Watts
Full Load Power Input	2.9 Amp at 115V
Control	Model N12-UN-6A
Net Feeder Weight	70 lb. (32 kg)

### MODEL 36C

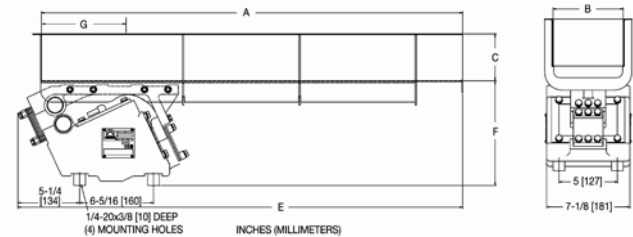

TRAY TYPE	A Tray Length		B Tray Width		C	
	in	mm	in	mm	in	mm
Narrow Flat	36	914	6	152	4	102
Medium Flat	30	762	8	203	4	102
Wide Flat	24	610	10	254	4	102
Small Tubular	30	762	3	76	3	76
Large Tubular	24	610	4	102	4	102

TRAY TYPE	D		E		F		G	
	in	mm	in	mm	in	mm	in	mm
Narrow Flat	12-15/16	328	38	966	8-15/16	226	8-15/16	226
Medium Flat	12-15/16	328	35	889	8-15/16	226	8-15/16	226
Wide Flat	12-15/16	328	31-3/4	807	8-15/16	226	8-15/16	226
Small Tubular	13-1/8	333	34-9/16	878	6	152	9 1/8	232
Large Tubular	13-1/16	332	28-5/16	719	8	203	9 1/8	232

Available for Class II, Division I, Group F, G Environments.



## Model 48A

FOR FEEDING UP TO 12 TONS (10.9 MT) PER HOUR

No rectifiers are needed with this Hi-Vi feeder. Merely wire into any AC line. A full feed range is provided by potentiometer or variable auto-transformer type controls. Varying the applied line voltage from zero to 100% allows precise feeding from a few ounces to 12 tons per hour.



Power Supply	115V, 60 Cycle, Single Phase
Full Load Power Consumption	38 Watts
Full Load Power Input	2.0 Amp at 115V
Control	Model FT
Net feeder Weight	100 lb. (45 kg)

## Specifications

### MODEL 48A

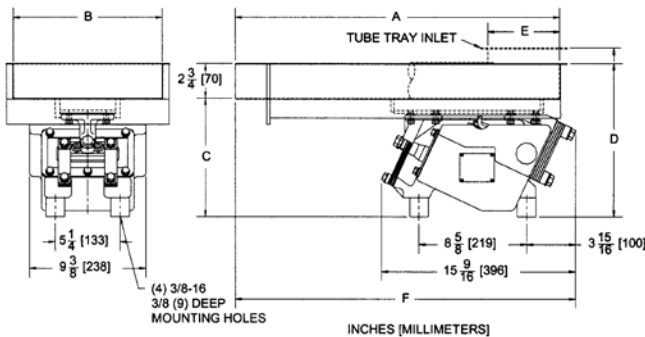

TRAY TYPE	A Tray Length		B Tray Width		C	
	in	mm	in	mm	in	mm
Narrow Flat	36	914	8	203	9-3/8	238
Medium Flat	30	762	12	305	9-3/8	238
Wide Flat	24	610	14	356	9-3/8	238

TRAY TYPE	D		E		F	
	in	mm	in	mm	in	mm
Narrow Flat	7-1/2	191	-	-	-	-
Narrow Flat	12-1/8	308	-	-	36-5/8	930
Medium Flat	12-1/8	308	-	-	31	787
Wide Flat	12-1/8	308	-	-	27-3/8	721

## Model 46C

FOR FEEDING UP TO 15 TONS (13.6 MT) PER HOUR

Rugged construction make this an ideal unit for medium duty industrial applications in food plants, chemical, pharmaceuticals, abrasives, plastics and other applications that demand the most precise control.



Power Supply	115V, 60 Cycle, Single Phase
Full Load Power Consumption	58 Watts
Full Load Power Input	4.2 Amp at 115V
Control	Model N12-UN-6A
Net Feeder Weight	135 lb. (61 kg)

### MODEL 46C

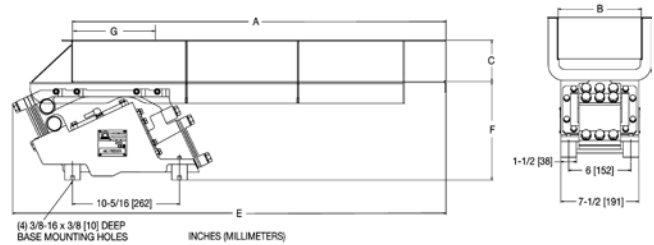

TRAY TYPE	A Tray Length		B Tray Width		C	
	in	mm	in	mm	in	mm
Narrow Flat	36	914	8	203	4	102
Wide Flat	30	762	12	305	4	102
Small Tubular	36	914	4	102	4	102
Large Tubular	30	762	6	152	6	152

TRAY TYPE	D		E		F		G	
	in	mm	in	mm	in	mm	in	mm
Narrow Flat	13-7/16	342	41-3/4	1061	9-7/16	240	-	-
Wide Flat	13-7/8	353	39-1/4	997	9-7/8	251	-	-
Small Tubular	15	382	38-1/8	968	10	254	8	203
Large Tubular	17	432	38-9/16	980	10	254	8	203

Available for Class II, Division I, Group F, G Environments.



## Model 56C

FOR FEEDING UP TO 20 TONS (18.1 MT) PER HOUR

Using Eriez' unique energy efficient AC drive, the Model 56C Vibratory Feeder has been computer designed to meet the most rigorous of international standards to keep pace with the future of industrial equipment.



Power Supply	115V, 60 Cycle, Single Phase
Full Load Power Consumption	75 Watts
Full Load Power Input	6.6 Amp at 115V
Control	Model N12-UN-15A
Net Feeder Weight	192 lb. (87 kg)

## Model 66C

FOR FEEDING UP TO 25 TONS (22.7 MT) PER HOUR

Rugged construction makes this an ideal unit for medium duty industrial applications in food plants, chemicals, pharmaceuticals, abrasives, plastics and other applications that demand the most precise control.



Power Supply	115, 60 Cycle, Single Phase
Full Load Power Consumption	90 Watts
Full Load Power Input	8.25 Amp at 115V
Control	Model N12-UN-15A
Net Feeder Weight	290 lb. (142 kg)

## Specifications

### MODEL 56C

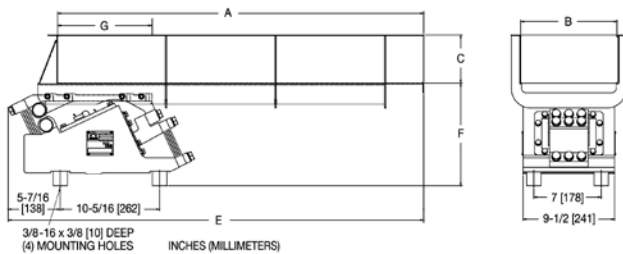

TRAY TYPE	A Tray Length		B Tray Width		C	
	in	mm	in	mm	in	mm
Narrow Flat	38	965	10	254	4	102
Medium Flat	30	762	14	356	4	102
Wide Flat	24	610	17	432	4	102
Small Tubular	48	1219	4	102	4	102
Med. Tubular	42	1067	6	152	6	152
Large Tubular	38	965	8	203	8	203

TRAY TYPE	D		E		F		G	
	in	mm	in	mm	in	mm	in	mm
Narrow Flat	15-5/8	397	43-1/8	1096	10-5/8	270	-	-
Medium Flat	15-5/8	397	39-1/8	994	10-5/8	270	-	-
Wide Flat	14-5/8	372	29-7/16	748	10-5/8	270	-	-
Small Tubular	15-5/8	397	51-9/16	1310	10-5/8	270	8	203
Med. Tubular	18-1/8	460	45-3/4	1162	12-1/8	270	12	304
Large Tubular	20-3/8	518	41-7/16	1053	12-5/8	276	16	406

Available for Class II, Division I, Group F, G Environments.

### MODEL 66C

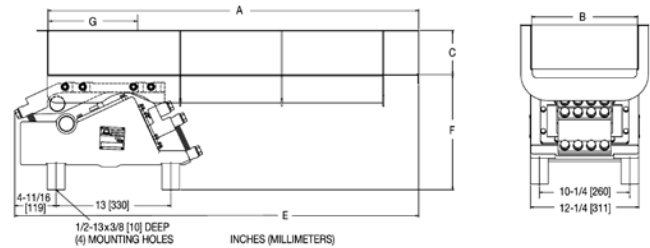

TRAY TYPE	A Tray Length		B Tray Width		C	
	in	mm	in	mm	in	mm
Narrow Flat	42	1067	12	305	5	127
Medium Flat	36	914	14	356	5	127
Wide Flat	30	762	16	406	5-1/2	140

TRAY TYPE	D		E		F		G	
	in	mm	in	mm	in	mm	in	mm
Narrow Flat	18	458	45-3/4	1163	13	330	-	-
Medium Flat	18	458	43-3/4	1112	13	330	-	-
Wide Flat	17-1/32	433	41-3/8	1051	13-1/32	330	-	-

Available for Class II, Division I, Group F, G Environments.



## Model 52A

FOR FEEDING UP TO 25 TONS (22.7 MT) PER HOUR

This compact but heavy duty unit is ideal for handling abrasives, slag, coal, grain, or wherever precisely controlled feeding of large volumes of dry bulk materials is required. The patented Eriez permanent magnet/ electromagnet AC drive results in greatly reduced power consumption compared to competitor's units which require a rectifier power source. The simplicity of the drive virtually eliminates maintenance.



Power Supply	115V or 230V 60 Cycle, Single Phase
Full Load Power Consumption	60 Watts
Full Load Power Input	4 Amp at 115V
Control	Model N12-UN-6A
Net Feeder Weight	165 lb. (79 kg)

## Specifications

### MODEL 52A

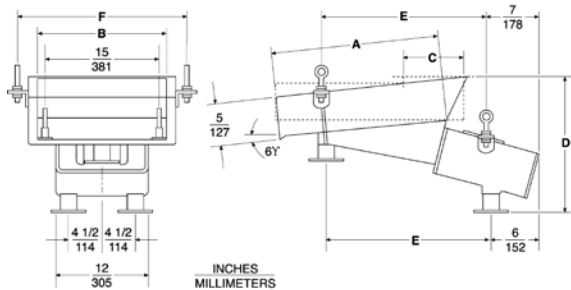

TRAY TYPE	A		B		C	
	Tray Length		Tray Width		in	mm
	in	mm	in	mm	in	mm
Narrow Flat	36	914	8	203	-	-
Medium Flat	24	610	12	305	-	-
Wide Flat	22	559	17	432	-	-
Tubular	48	1219	4	102	8	203
Tubular	42	1067	6	152	12	305
Half Round	36	914	8	203	12	305

TRAY TYPE	D		E		F	
	in	mm	in	mm	in	mm
Narrow Flat	19-1/2	495	35-1/4	659	13-1/4	337
Medium Flat	17-1/2	445	23-3/4	603	17-1/4	438
Wide Flat	17-1/2	445	21-3/4	552	22-1/4	565
Tubular	18-1/4	464	30	762	9	229
Tubular	20-3/4	527	33-3/4	857	11	279
Half Round	23-1/4	591	30-1/4	768	13	330

Available for Class II, Division I, Group F, G Environments.





# High Speed Electromagnetic

Eriez AC operated Hi-Speed Feeders have been designed for exceptionally high speed feeding of light, bulky materials. They provide greater economy and efficiency in feeding, filling, etc., and are ideal for use in conjunction with many weigh scale and packaging machines.

The HS-5 Feeder is capable of moving a great variety of materials at speeds up to 75 feet (23 meters) per minute. The other Hi-Vi Feeders are capable of speeds up to 60 feet (18 meters) per minute. Feed rate is simply adjusted by Eriez' variable transformer type controller. The units are light and functional and can be installed easily in a minimum of space in conjunction with other equipment – operation is virtually silent!

These feeders operate at speeds up to 75% greater than standard models; however, they do follow many of the basic tried and proven mechanical design and construction features of other Hi-Vi Feeders.

## Spring System

The spring system consists primarily of an elastomeric torsion spring having high damping properties and so designed that high deflections can be tolerated without danger of early failure. Besides being tolerant of high deflection, the high damping characteristic of the elastomeric torsion spring makes it possible to operate on a broad, almost flat area at the top of the tuning curve. This makes it possible to drive the moving assembly at high deflections with maximum stability and minimum input power.

An added and important feature of the elastomeric spring is its quick-stopping characteristic due to the extremely rapid decay of vibratory energy when the unit is de-energized. This characteristic is useful in such product applications as packaging where overruns of material cannot be tolerated.

## Simple Tuning

Easily adaptable for a greater variety of tray sizes and weights. Tuning, when required, is accomplished through simple replacement of an easily accessible glass fiber tuning spring. No other adjustment is necessary. Simple, clean lines—no pockets and crevices—reduces foreign matter accumulation.

Trays are of welded construction and are available in regular mild steel or 304 stainless. Rubber isolators are standard; coil spring isolators are also available.

## Model HS-8 Feeder Drive

FOR CUSTOMER TRAYS FROM 4 – 8 LBS (1.8 – 3.6 KG)



Power Supply	115V., 60 Cycles, Single Phase	
Full Load Power Consumption	40 Watts	
Full Load Input - 115V.	1.5 Amp.	
Control	Unicon	
Net Weight (without control box)	23 lb.	10.4 kg
Weight (with control box)	29 lb.	13 kb

\*Typical Tray Weight 4 to 8 Lbs.

## Specifications

### MODEL HS-8

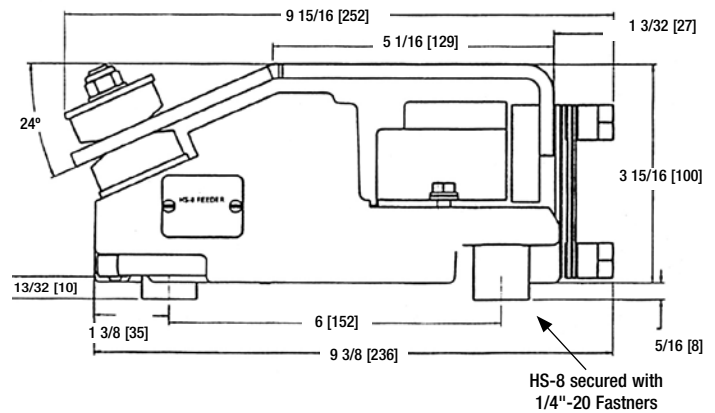

## Revolutionary Tuning

Designed with packaging machine manufacturers in mind, the HS-8 is easily adaptable to a great variety of tray sizes and weights. Once the tray is mounted to the drive, coarse tuning is accomplished simply by replacement of easily accessible glass fiber tuning springs. Fine tuning is achieved by changing the compression of the rubber elastomeric spring. With E-Z Tune technology incorporated, simple turning of a wrench adjusts the specially compounded rubber elastomeric tuning spring at the rear of the feeder drive. Increasing or decreasing the compression adjusts the vibration level.





## Model HS-10

FOR FEEDING UP TO 80 CU FT (2.3 M3) PER HOUR



Power Supply	115V, 60 Cycle, Single Phase
Full Load Power Consumption	40 Watts
Full Load Power Input	1.0 Amp at 115V
Control	Model FT-115
Net Feeder Weight	25 lb. (11 kg)

## Model HS-26

FOR FEEDING UP TO 120 CU FT/HR (3.4 M3/HR)

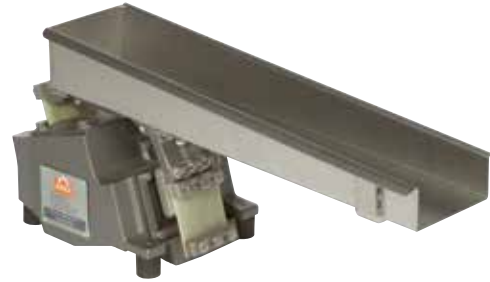

Power Supply	115V, 60 Cycle, Single Phase
Full Load Power Consumption	37 Watts
Full Load Power Input	1.2 Amp at 115V
Control	Model FT-115
Net Feeder Weight	42 lb. (19 kg)

## Specifications

### MODEL HS-10

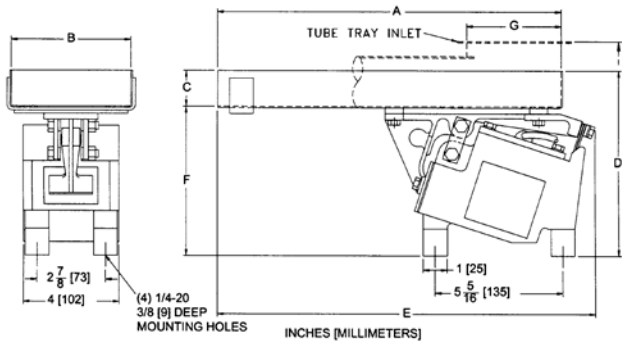

TRAY TYPE	A		B		C	
	Tray Length		Tray Width			
	in	mm	in	mm	in	mm
Narrow Flat	18	457	3	76	1	25
Wide Flat	12	305	6	152	1-1/4	32
90 Degree V	18	457	3	76	1	25
Half Round	18	457	3	76	1-1/2	38
Tubular	17	432	3	76	2	51

TRAY TYPE	D		E		F		G	
	in	mm	in	mm	in	mm	in	mm
Narrow Flat	7-1/4	184	19-7/16	494	6-1/4	159	-	-
Wide Flat	7-1/2	191	14-1/2	368	6-1/4	159	-	-
90 Degree V	8-5/16	211	19-7/16	494	6-5/16	161	-	-
Half Round	7-3/8	187	19-3/4	502	5-7/8	149	-	-
Tubular	8-1/4	210	18-3/4	476	6-1/4	159	4	102

### MODEL HS-26

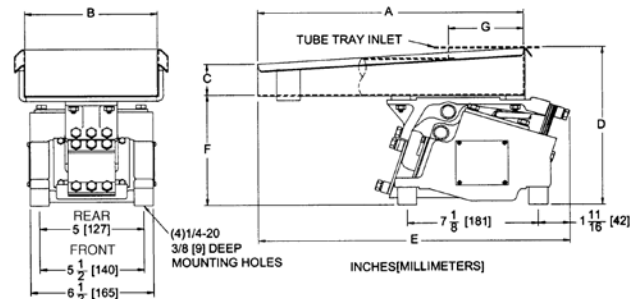

TRAY TYPE	A		B		C	
	Tray Length		Tray Width			
	in	mm	in	mm	in	mm
Narrow Flat	20	508	4	102	1-3/4	44
Medium Flat	22	559	5	127	1-3/4	44
Wide Flat	14	356	7	178	1-3/4	44
Wide Flat	20	508	7	178	1-3/4	44
90 Degree V	20	508	3	76	1-1/2	38
90 Degree V	20	508	4	102	2	51
Small Tubular	19	483	2	51	2	51
Large Tubular	19	483	3	76	3	76

TRAY TYPE	D		E		F		G	
	in	mm	in	mm	in	mm	in	mm
Narrow Flat	8-7/8	225	22-3/8	568	6-1/4	159	-	-
Medium Flat	9	229	22	559	6-1/4	159	-	-
Wide Flat	8-7/8	225	16-3/8	416	6-1/4	159	-	-
Wide Flat	9	229	20	509	6-1/4	159	-	-
90 Degree V	8-13/16	224	22-3/8	568	6-5/16	160	-	-
90 Degree V	9-3/8	237	20	509	6-3/8	161	-	-
Small Tubular	8-3/4	222	21-3/8	543	6-1/4	159	4	102
Large Tubular	10	254	19	484	6-1/4	159	6	152

Available for Class II, Division I, Group F, G Environments.



## Model HS-36

FOR FEEDING UP TO 200 CU FT/HR (5.7 M3) PER HOUR



Power Supply	115V, 60 Cycle, Single Phase
Full Load Power Consumption	75 Watts
Full Load Power Input	2.2 Amp at 115V
Control	Model N12-UN-6A
Net Feeder Weight	70 lb. (32 kg)

## Model HS-42

FOR FEEDING UP TO 200 CU FT (5.7 M3) PER HOUR

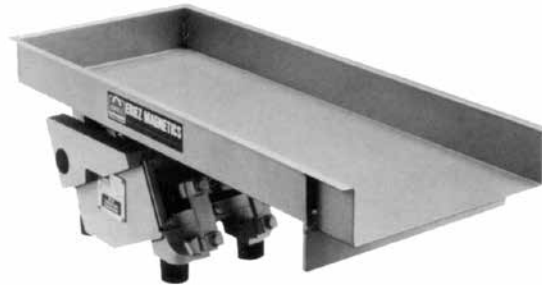

Power Supply	115V, 60 Cycle, Single Phase
Full Load Power Consumption	38 Watts
Full Load Power Input	2.0 Amp at 115V
Control	Model FT-115
Net Feeder Weight	100 lb. (45 kg)

## Specifications

### MODEL HS-36

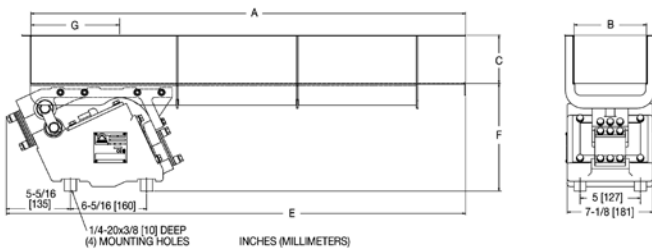

TRAY TYPE	A Tray Length		B Tray Width		C Tray Width	
	in	mm	in	mm	in	mm
Narrow Flat	36	914	6	152	4	102
Medium Flat	30	762	8	203	4	102
Wide Flat	24	610	10	254	4	102
Small Tubular	30	762	3	76	3	76
Large Tubular	24	610	4	102	4	102

TRAY TYPE	D		E		F	
	in	mm	in	mm	in	mm
Narrow Flat	12-15/16	328	30-1/16	963	8-15/16	226
Medium Flat	12-15/16	328	35	887	8-15/16	226
Wide Flat	12-15/16	328	31-3/4	753	8-15/16	226
Small Tubular	13-1/8	333	34-9/16	878	9-1/8	232
Large Tubular	14-1/16	357	28-9/16	726	9-1/8	232

### MODEL HS-42

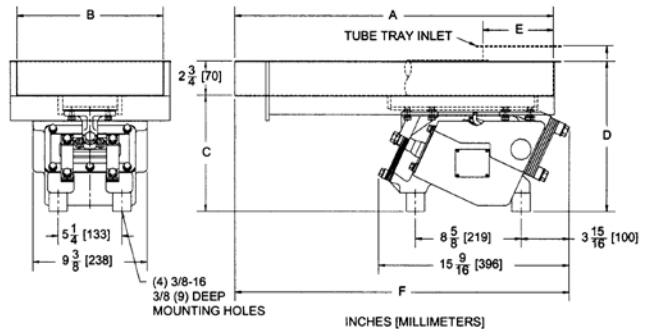

TRAY TYPE	A Tray Length		B Tray Width		C	
	in	mm	in	mm	in	mm
Narrow Flat	36	914	8	203	9-3/8	238
Medium Flat	30	762	12	305	9-3/8	238
Wide Flat	24	610	14	356	9-3/8	238

TRAY TYPE	D		E		F	
	in	mm	in	mm	in	mm
Narrow Flat	7-1/2	191	-	-	-	-
Narrow Flat	12-1/8	308	-	-	36-5/8	930
Medium Flat	12-1/8	308	-	-	31	787
Wide Flat	12-1/8	308	-	-	27-3/8	721

Available for Class II, Division I, Group F, G Environments.



## Model HS-46

FOR FEEDING UP TO 365 CU FT (10.3 M3) PER HOUR



Power Supply	115V, 60 Cycle, Single Phase
Full Load Power Consumption	107 Watts
Full Load Power Input	2.4 Amp at 115V
Control	Model N12-UN-6A
Net Feeder Weight	135 lb. (61 kg)

## Model HS-56

FOR FEEDING UP TO 400 CU FT (11.3 M3) PER HOUR



Power Supply	115V, 60 Cycle, Single Phase
Full Load Power Consumption	108 Watts
Full Load Power Input	2.6 Amp at 115V
Control	Model N12-UN-6A
Net Feeder Weight	192 lb. (87 kg)

## Specifications

### MODEL HS-46

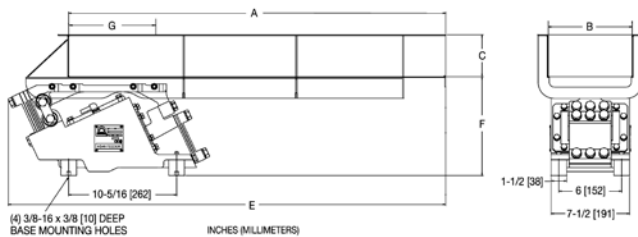

TRAY TYPE	A Tray Length		B Tray Width		C	
	in	mm	in	mm	in	mm
Narrow Flat	36	914	8	203	4	102
Wide Flat	30	762	12	305	4	102
Small Tubular	36	914	4	102	4	102
Large Tubular	30	762	6	152	6	152

TRAY TYPE	D		E		F		G	
	in	mm	in	mm	in	mm	in	mm
Narrow Flat	13-7/16	342	41-3/4	1061	9-7/16	240	-	-
Wide Flat	13-7/8	353	39-3/16	995	9-7/8	251	-	-
Small Tubular	15	382	38-1/8	968	10	254	8	203
Large Tubular	17-1/2	445	38-9/16	980	10	254	8	203

Available for Class II, Division I, Group F, G Environments.

### MODEL HS-56

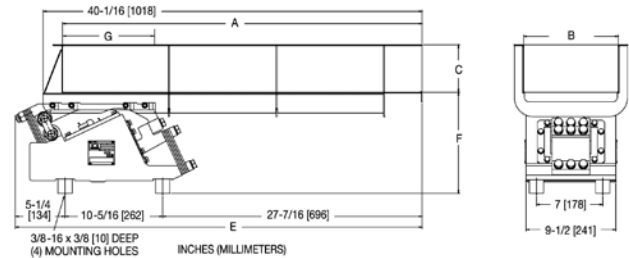

TRAY TYPE	A Tray Length		B Tray Width		C	
	in	mm	in	mm	in	mm
Narrow Flat	38	965	10	254	5	127
Medium Flat	30	762	14	356	5	127
Wide Flat	24	610	17	432	4	102
Small Tubular	48	1219	4	102	4	102
Med. Tubular	42	1067	6	152	6	152
Large Tubular	38	965	8	203	8	203

TRAY TYPE	D		E		F		G	
	in	mm	in	mm	in	mm	in	mm
Narrow Flat	15-5/8	397	43	1092	10-5/8	270	-	-
Medium Flat	15-5/8	397	39	990	10-5/8	270	-	-
Wide Flat	14-5/8	397	29-7/16	748	10-5/8	270	-	-
Small Tubular	15-5/8	397	51-9/16	1310	10-5/8	270	8	203
Med. Tubular	18-1/8	460	45-9/16	1154	10-5/8	270	12	304
Large Tubular	20-3/8	518	41-7/16	1053	10-7/8	276	16	406

Available for Class II, Division I, Group F, G Environments.



## Model HS-66

FOR FEEDING UP TO 600 CU FT (17 M3) PER HOUR



Power Supply	115V, 60 Cycle, Single Phase
Full Load Power Consumption	104 Watts
Full Load Power Input	3.2 Amp at 115V
Control	Model N12-UN-6A
Net Feeder Weight	290 lb. (132 kg)

## Specifications

### MODEL HS-66

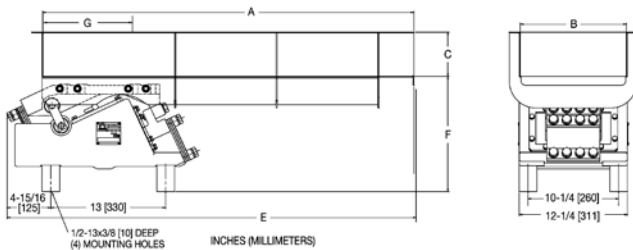

TRAY TYPE	A Tray Length		B Tray Width		C	
	in	mm	in	mm	in	mm
Narrow Flat	42	1067	12	305	4	102
Medium Flat	36	914	14	356	4	102
Wide Flat	30	762	16	406	5-1/2	140

TRAY TYPE	D		E		F		G	
	in	mm	in	mm	in	mm	in	mm
Narrow Flat	18-1/2	470	47	1194	13	330	-	-
Medium Flat	18-1/2	470	44-1/2	1130	13	330	-	-
Wide Flat	18-1/2	470	41-3/8	1051	13	330	-	-

Available for Class II, Division I, Group F, G Environments.

# High Deflection Electromagnetic

The new Model HD “High Deflection” Vibratory Feeder is the result of years of research to combine the higher deflection of up to 3/16-inch (4.8 mm) and lower frequency (30 cps) advantages of a mechanical feeder with the trouble-free service of an electromagnetic feeder.

Eriez unique AC drive is further enhanced by a unique patented armature design that reduces power consumption by 75% and allows the drive to be exceptionally powerful for its size.

The Model HD is designed to handle powders and leafy products that normally could not be fed successfully in an electromagnetic feeder. Feed rates of up to 80 feet per minute (24 m/min) are possible for products with a bulk density less than 10 lb/ft<sup>3</sup> (.16 gm/cc).

The Model HD-C is designed for high amplitude and 30 cps operation where the feed may see higher material loads.

The elastomeric torsion spring provides quick stopping characteristics and protects the fiberglass springs from damage due to overstressing.

Standard control for the Model HD Feeder is Eriez’ N12G30Hz-115 solid state control. The control can vary the feed rate from zero to 100%, giving 100% range of capability. This control is housed in an NEMA 12 Type enclosure to ensure years of trouble-free service.

All units are enclosed—dust and moisture resistant. Dust – tight and epoxy – coated units are available. Patent pending electromagnetic drive utilizes rare earth magnetic technology to produce a large displacement and low power consumption (25% of normal electromagnetic drives). This revolutionary drive has an operating frequency of 30 Hz and imitates the motion of a mechanical vibrating feeder with the control of an electromagnetic feeder. Epoxy-encapsulated coil and magnet eliminate coil movement, extending trouble-free coil life. Fiberglass springs give long spring life and are not subject to corrosion. Units are base mounted. Feeder base comes with rubber isolation mounts. Trays are available in mild steel and stainless steel.

Due to the unique operating characteristics of Eriez’ high deflection feeders, it is suggested that you send a sample of your material for feed rate conformation.



## Model HD-36 & HD-36C

FOR FEEDING UP TO 150 CU FT/HR (8.5 M3) PER HOUR



	HD-36	HD-36C
Power Supply	115V, 40 Cycle, Single Phase	115V, 40 Cycle, Single Phase
Full Load Power Consumption	71 Watts	38 Watts
Full Load Power Input	2.5 Amps	2.9 Amps
Control	Model N12G40Hz-115	
Net Feeder Weight	120 lb. (54 kg)	

Available for 115 or 230 V operation

## Specifications

### MODEL HD-36

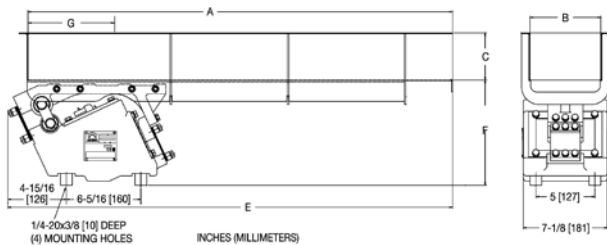

TRAY TYPE	A		B		C	
	Tray Length		Tray Width			
	in	mm	in	mm	in	mm
Narrow Flat	36	914	6	152	4	102
Medium Flat	30	762	8	203	4	102
Wide Flat	24	610	10	254	4	102
Small Tubular	30	762	3	76	3	76
Large Tubular	24	610	4	102	4	102

TRAY TYPE	D		E		F		G	
	in	mm	in	mm	in	mm	in	mm
Narrow Flat	12-15/16	328	37-11/16	958	8-15/16	226	9	229
Medium Flat	12-15/16	328	34-11/16	882	8-15/16	226	9	229
Wide Flat	12-15/16	328	31-7/16	799	8-15/16	226	9	229
Small Tubular	13-1/16	331	34-1/4	870	6	152	9-1/16	230
Large Tubular	14-1/16	357	28-1/4	717	8	203	9-1/16	230

Available for Class II, Division I, Group F, G Environments.

## Model HD-46 & HD-46C

FOR FEEDING UP TO 400 CU FT (11 M3) PER HOUR



	HD-46	HD-46C
Power Supply	115V, 30 Cycle, Single Phase	115V, 30 Cycle, Single Phase
Full Load Power Consumption	106 Watts	58 Watts
Full Load Power Input	1.5 Amps	4.2 Amps
Control	Model N12G30Hz-115	
Net Feeder Weight	135 lb. (61 kg)	

Available for 115 or 230 V operation

### MODEL HD-46

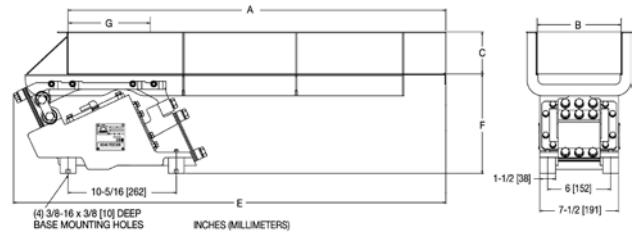

TRAY TYPE	A		B		C	
	Tray Length		Tray Width			
	in	mm	in	mm	in	mm
Narrow Flat	36	914	8	203	4	102
Wide Flat	30	762	12	305	4	102
Small Tubular	36	914	4	102	4	102
Large Tubular	30	762	6	152	6	152

TRAY TYPE	D		E		F		G	
	in	mm	in	mm	in	mm	in	mm
Narrow Flat	13-7/16	342	41-3/16	1046	9-7/16	240	-	-
Wide Flat	13-7/8	351	38-5/8	982	9-7/8	251	-	-
Small Tubular	14-3/16	360	37-9/16	954	9-3/16	233	8	203
Large Tubular	16-5/16	440	38-1/16	987	9-13/16	250	8	203

Available for Class II, Division I, Group F, G Environments.



## Model HD-56 & HD-56C

FOR FEEDING UP TO 500 CU FT (14 M3) PER HOUR



	HD-56	HD-56C
Power Supply	115V, 30 Cycle, Single Phase	115V, 30 Cycle, Single Phase
Full Load Power Consumption	95 Watts	75 Watts
Full Load Power Input	1.5 Amps	6.6 Amps
Control	Model N12G30Hz-115	
Net Feeder Weight	192 lb. (87 kg)	

Available for 115 or 230 V operation

## Model HD-66 & HD-66C

FOR FEEDING UP TO 700 CU FT (20 M3) PER HOUR



	HD-66	HD-66C
Power Supply	115V, 30 Cycle, Single Phase	115V, 30 Cycle, Single Phase
Full Load Power Consumption	165 Watts	90 Watts
Full Load Power Input	2.6 Amps	8.25 Amps
Control	Model N12G30Hz-115	
Net Feeder Weight	290 lb. (142 kg)	

Available for 115 or 230 V operation

## Specifications

### MODEL HD-56

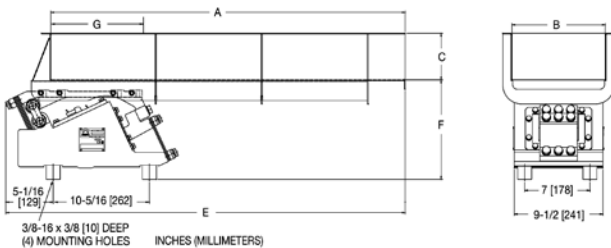

TRAY TYPE	A		B		C	
	Tray Length		Tray Width			
	in	mm	in	mm	in	mm
Narrow Flat	38	965	10	254	5	127
Medium Flat	30	762	14	356	5	127
Wide Flat	24	610	17	432	5	127
Small Tubular	48	1219	4	102	4	102
Med. Tubular	42	1067	6	152	6	152
Large Tubular	38	965	8	203	8	203

TRAY TYPE	D		E		F		G	
	in	mm	in	mm	in	mm	in	mm
Narrow Flat	15-5/8	397	42-13/16	1053	10-5/8	270	-	-
Medium Flat	15-5/8	397	38-13/16	1000	10-5/8	270	-	-
Wide Flat	16-1/8	410	29-7/16	748	10-5/8	270	-	-
Small Tubular	15-5/8	397	51-9/16	1310	10-5/8	270	8	203
Med. Tubular	18-1/8	460	45-1/4	1149	11-1/8	284	12	304
Large Tubular	20-3/8	518	40-15/16	1039	10-7/8	276	16	406

Available for Class II, Division I, Group F, G Environments.

### MODEL HD-66

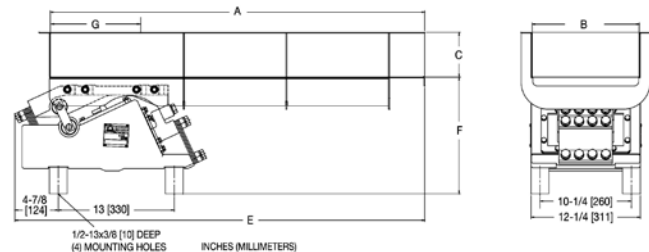

TRAY TYPE	A		B		C	
	Tray Length		Tray Width			
	in	mm	in	mm	in	mm
Narrow Flat	42	1067	12	305	4	102
Medium Flat	36	914	14	356	4	102
Wide Flat	30	762	16	406	5-1/2	140

TRAY TYPE	D		E		F		G	
	in	mm	in	mm	in	mm	in	mm
Narrow Flat	18	458	45-15/16	1164	13-1/32	331	-	-
Medium Flat	18	458	43-15/16	1117	13-1/32	331	-	-
Wide Flat	18-17/32	471	41-3/8	1051	13-1/32	331	-	-

Available for Class II, Division I, Group F, G Environments.



# Designing for Special Application Requirements

Eriez' experience in designing unique feeder units and trays for special applications, plus computerization of vibratory feeder variables, means that unusual requirements can be met quickly and economically.

Meeting non-typical requirements for unique applications is common of Eriez. Experienced engineers, production specialists and state-of-the-art manufacturing easily handle difficult tasks.



Tubular trays – part of an enclosed system used for hot or gassy products – are a standard option on most Eriez Hi-Vi feeders.



Eriez Vibratory Feeders serve as efficient screen separators. Scalping, sizing and de-dusting can be achieved with our vibratory screens. Screeners such as this HD-66 with tool-less screen removal are sanitary and user friendly.



Feeders with tube trays such as the 56C are used when handling dusty materials and also to protect sensitive products from outside contamination. Multiple drives arranged longitudinally either above or below tray make efficient conveyors in lengths up to 20 feet (6 meters).



Long narrow trays can be furnished to form vibratory conveyors. They can be supplied in other shapes as well, such as tubular, "V-type" and half round. They can be lined or coated to offset abrasion or noise. Many other variations are also available.





# Hi-Vi Volumatic Feeder Machines

Eriez Hi-Vi Volumatic Feeder Machines provide dual vibratory action to assure the proper flow of dry bulk material for measured discharge rates.

These one-piece, compact, rugged assemblies are ideal for use in conduction with weigh scales, packaging and bagging equipment, small batch operations, and where additive feeding is being performed either continuously or intermittently.

Each Hi-Vi Volumatic Feeder Machine has been scientifically designed in size, shape and vibratory action to give you the most efficient precision feeding possible. Models are available in three popular sizes, with variable feed rates ranging from a few pounds to 15 tons per hour.

## Operating Benefits

Positive control of feed, so important to packaging and bagging operations, is assured by the elimination of rear-end dead spots and front-end flip. The rugged hopper with adjustable discharge spout is easily removed from the frame for cleaning. All models are available for dusty locations—and as specially constructed units for installation in those areas where Class II, Group G equipment is normally used.

Eriez' standard line of Hi-Vi Feeders and Bin Vibrators with their proven, exclusive construction features and operating advantages are the components used to make these feeder machine assemblies.

All models are furnished with compact, maintenance-free, variable transformer type AC controls. The box can be installed on the frame of the unit or remotely in any convenient location. The controller can be furnished with a dual control for "fast" and "dribble" feed rates where necessary. Various timers are available for any number of timed or intermittent feeding phases.

The Eriez Hi-Vi drive system, based on a permanent magnet, replaces rectifiers by providing an inherent rectification system. This means more operating forces, no energy lost to the rectifier, more efficiency.

## Entirely Enclosed Unit

The Hi-Vi Vibratory Feeders and Bin Vibrators used in these Feeder Machines are entirely enclosed. The feeder is so designed that the drive elements are completely protected against damage or decreased efficiency due to contamination by moisture and foreign materials.

## Uniformity of Feed

The Feeders are designed to produce the most uniform feed possible, consistent with the wide variety of existing field applications. They provide instant starts and stops with a minimum of product carry-over.

## Operation

In operation, the adjustable spout at the bottom of the hopper can be adjusted as required to obtain the optimum depth of flow. Once this has been established and the adjustable spout secured, the best feed and vibration rates of the feeder and the unit vibrator can be obtained by adjusting the double controller.

Timing and/or dual feeder control functions can be obtained with special controllers designed to provide such functions.



## Special Feeder Machines









# Controls

## FT-115

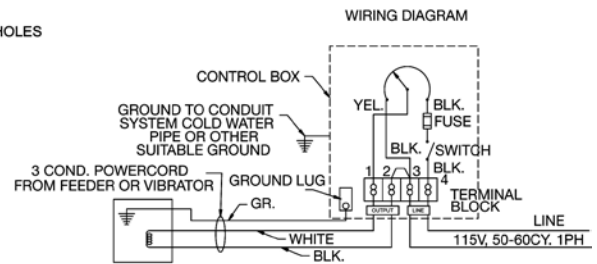
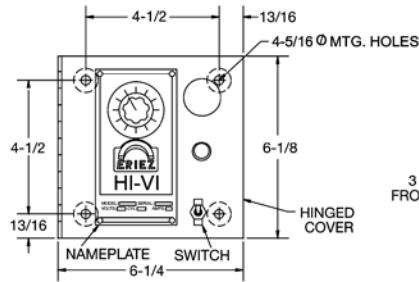

### Features

- Standard NEMA 1 enclosure
- Variable transformer adjustment
- Excellent linearity adjustment
- 115 volt operation (2 amp rating)

## UNICON

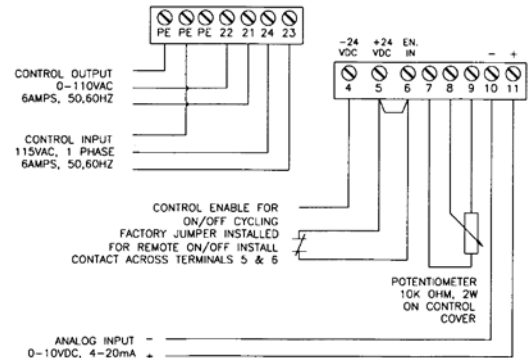
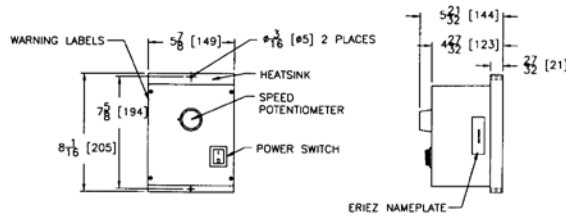

### Features

- Standard NEMA 12 enclosure (IP54) NEMA 4X and chassis mount available
- Solid-state design
- Remote on/off
- Analog signal capable
- 115 or 230 volt operation (2 to 15 amp models)

## G30Hz

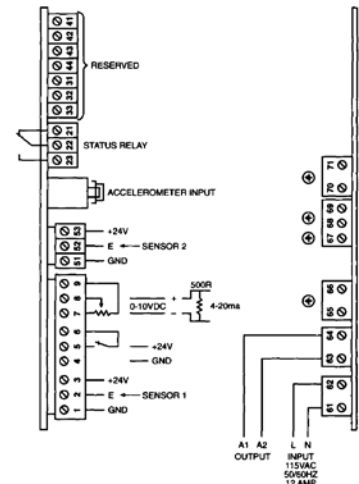
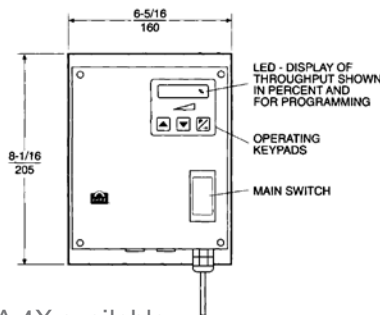

### Features

- Standard NEMA 12 enclosure (IP54)NEMA 4X available
- Solid-state design
- Remote on/off
- Analog signal capable
- Tray deflection monitoring available
- 115 or 230 volt operation (12 amp rating)



# Preliminary Vibratory Specification Sheet

## Contact Information

DATE: \_\_\_\_\_  
 CUSTOMER NAME: \_\_\_\_\_  
 ADDRESS: \_\_\_\_\_  
 CITY: \_\_\_\_\_ STATE: \_\_\_\_\_ ZIP: \_\_\_\_\_  
 CONTACT: \_\_\_\_\_ PHONE: \_\_\_\_\_  
 TITLE: \_\_\_\_\_ EMAIL: \_\_\_\_\_

## Application Details

MATERIAL SUPPLIED FROM: \_\_\_\_\_ NO. OF UNITS: \_\_\_\_\_  
 FEEDER DISCHARGES TO: \_\_\_\_\_  
 MATERIAL TO BE HANDLED: \_\_\_\_\_  
 BULK DENSITY: \_\_\_\_\_ PRODUCT TEMP: \_\_\_\_\_  
 CAPACITY: \_\_\_\_\_ AMBIENT TEMP: \_\_\_\_\_  
 PARTICLE SIZE: \_\_\_\_\_ ABBRASIVE: \_\_\_\_\_  
 ANGLE OF REPOSE: \_\_\_\_\_ MOISTURE %: \_\_\_\_\_

## Equipment Design

OPERATING VOLTAGE: VOLTAGE: \_\_\_\_\_ HZ: \_\_\_\_\_  
 IS FEEDER CYCLED ON/OFF: NO: \_\_\_\_\_ YES: \_\_\_\_\_ HOW OFTEN: \_\_\_\_\_  
 DRIVE LOCATION: BELOW TRAY: \_\_\_\_\_ ABOVE TRAY: \_\_\_\_\_  
 MOUNTING: BASE: \_\_\_\_\_ SUSPENSION: \_\_\_\_\_  
 TRAY SIZE: WIDTH: \_\_\_\_\_ LENGTH: \_\_\_\_\_ DEPTH: \_\_\_\_\_  
 TRAY TYPE: OPEN: \_\_\_\_\_ ENCLOSED: \_\_\_\_\_ TUBE: \_\_\_\_\_  
 OTHER: \_\_\_\_\_  
 IF ENCLOSED: INLET INFO: \_\_\_\_\_ OUTLET INFO: \_\_\_\_\_  
 TRAY MATERIAL: MILD STEEL: \_\_\_\_\_ 304 SS: \_\_\_\_\_ OTHER: \_\_\_\_\_  
 SANITARY CONSTRUCTION: NO: \_\_\_\_\_ YES: \_\_\_\_\_ DESCRIPTION: \_\_\_\_\_  
 \_\_\_\_\_

## Other Requirements

SCREEN: NO: \_\_\_\_\_ YES: \_\_\_\_\_ DESCRIPTION: \_\_\_\_\_  
 \_\_\_\_\_

## Control Requirements

CONTROL REQUIRED: NO: \_\_\_\_\_ YES: \_\_\_\_\_ NEMA ENCLOSURE TYPE: 1 12 4 4X SS  
 SIGNAL FOLLOWING: NO: \_\_\_\_\_ YES: \_\_\_\_\_ IF YES, 4-20 MA OR 0-10 VDC: \_\_\_\_\_

## Other Features

\_\_\_\_\_



# Vibratory Feeders At Work

Eriez Vibratory Feeders are at work in nearly every industry. Shown here are just a few of the many varied applications.



Eriez HS66 feeder accepting material from a vibratory Screener and discharging into a bucket elevator. The long tray overhang beyond the feeder drive and sanitary welding of the feeder tray help make this a clean installation.



HD66 feeders being used to convey and rotate product in an inspection line. The sanitary tray makes clean-up easy and the electromagnetic drive design virtually eliminates maintenance concerns.



An Eriez vibratory feeder is feeding toppings onto cookies. The precise feed of Eriez electromagnetic feeders provide the flow control needed to meet difficult quality control standards.



**World Authority in Separation Technologies**

Headquarters: 2200 Asbury Road, Erie, PA 16506-1402 U.S.A.

Telephone: 814-835-6000 • 800-345-4946 • Fax: 814-838-4960 • International Fax: 814-833-3348

Web Site: <http://www.eriez.com> e-mail: [eriez@eriez.com](mailto:eriez@eriez.com)

Manufacturing Facilities: AUSTRALIA • BRAZIL • CANADA • CHINA • INDIA • JAPAN • MEXICO • SOUTH AFRICA • UNITED KINGDOM • UNITED STATES

Eriez and Eriez Magnetics are registered trademarks of Eriez Manufacturing Co, Erie, PA

©2015 ERIEZ MAGNETICS

ALL RIGHTS RESERVED